

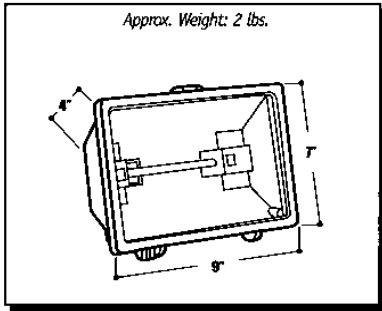

# ATLAS LIGHTING PRODUCTS



Catalog #	Description	Std. Pkg.
Q500WF	500W Quartz, Bronze Finish w/ Frame, 120V Lamp	12
Q500FWT	500W Quartz, White Finish w/ Frame, 120V Lamp	12

**Q500WF.....\$15.10 ea.**  
**Q500FWT.....\$15.10 ea.**

UL Listed for Ground Mounting  
 UL Listed for Wet Locations  
 Die Cast Aluminum  
 Hinged Frame with Spring Clasp  
 1/2" Adjustable Knuckle

Catalog #	Description	Volts	Std. Pkg.
Q1000FWL240	1000W Quartz, Bronze Finish w/ Frame	240	6
Q1500FWL240	1500W Quartz, Bronze Finish w/ Frame	240	6

**Q1000FWL240.....\$42.70 ea.**  
**Q1500FWL240.....\$42.70 ea.**

UL Listed for Ground Mounting  
 UL Listed for Wet Locations  
 Die Cast Aluminum  
 Hinged Frame with Spring Clasp  
 1/2" Adjustable Knuckle

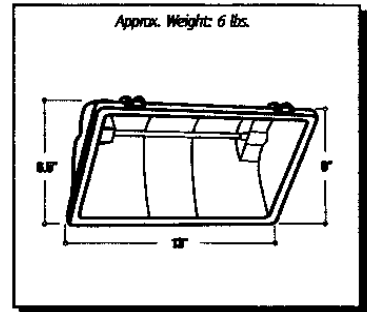

Die Cast Aluminum Housing  
 Large Oversized Adjustment Knob  
 Heat Resistant Wooden Handle  
 Weatherproof 2-Position Switch  
 Heavy Duty Steel Base with Non-Skid Grips  
 15' Heavy Duty Cord

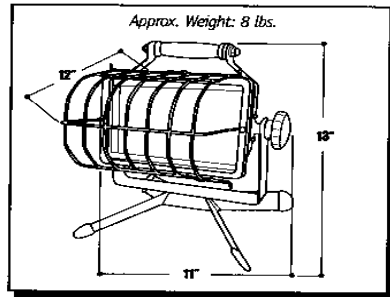

Catalog #	Description	Volts	Std. Pkg.
PCWL500QPK	500W Portable Quartz w/ Lamp	120	1

**PCWL500QPK.....\$31.95**

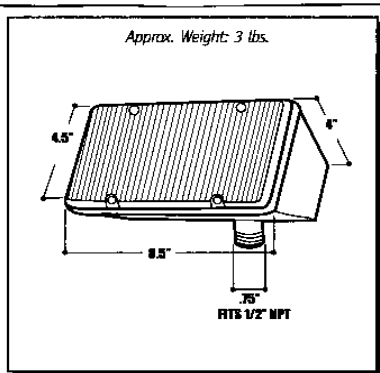

Description	Volts	Std. Pkg.
26 watt Floodlight, Bronze	120	12

**DFE213PK.....\$32.15**

UL Listed for Wet Locations  
 Uses 70% Less Energy than an Incandescent Lamp with the Same Light Output  
 Lamp Lasts up to 5 Times Longer Than Comparable Incandescent  
 Corrosion Resistant Housing  
 1/2" Threaded Adjustable Knuckle  
 Polycarbonate Lens